



# Product specifications 产 品 规 格 书

Model 型号: XC-ISR18650-2.6Ah

Customer 客户名称: \_\_\_\_\_

Qinhuangdao Xinchi Photoelectricity Technology Co, LTD

秦皇岛芯驰光电科技有限公司

Designed 制定	Checked 审核	Approved 批准

## 目 录

1. APPLICATION SCOPE 适用范围.....	2
2. DEFINITION 定义.....	2
3. MODEL AND DIMENSION 型号及尺寸.....	2
4. SPECIFICATION 规格.....	3
5. TECHNICAL CHARACTERISTICS 技术要求.....	3
6. CHARACTERISTICS CURVES 性能曲线（仅供参考）.....	7
7. STORAGE AND OTHERS 储存及其它事项.....	7
8. WARRANTY AND RESPONSIBILITY 保质期及产品责任.....	7
9. NOTICE IN USING BATTERY 电池操作注意事项.....	7
10. WARNING AND MATTERS NEED ATTENTION IN USING BATTERY 电池使用时警告事项及注意事项.....	8

## 1. Application Scope 适用范围

This product specification specifies characteristics of cylindrical lithium rechargeable battery manufactured by Qinhuangdao Xinchi Photoelectricity Technology Co, LTD

本产品规格书描述了秦皇岛芯驰光电科技有限公司（以下简称芯驰光电）生产的可充电圆柱锂离子电池的产品性能指标。

## 2. Definition 定义

### 2.1 Rated capacity 标称容量

Under  $20\pm 5^{\circ}\text{C}$ , It means the capacity value with a 5-hour rate discharging to end voltage 2.75 V, the unit is mAh.

指在  $20\pm 5^{\circ}\text{C}$  环境下，以 5 小时率放电至终止电压 2.75 V 时的容量，单位为毫安培时(mAh)。

### 2.2 Standard charge method 标准充电方式

Under  $20\pm 5^{\circ}\text{C}$ , charge the cell to 4.2V with constant current of 0.5C, and then, charge it continuously with constant voltage of 4.2V until the charge current is less than 0.01C.

指在  $20\pm 5^{\circ}\text{C}$  环境下，以 0.5C 的电流恒流充电至单体电芯电压 4.2 V 后，转为恒压 4.2 V 充电，至充电电流小于 0.02C 时，停止充电。

### 2.3 Standard discharge method 标准放电方式

Under  $20\pm 5^{\circ}\text{C}$ , it can be discharged to 2.75 V with constant current of 0.5C.

指在  $20\pm 5^{\circ}\text{C}$  环境下，以 0.5C 的电流恒流放电至单体电芯电压 2.75 V。

## 3. Model and Dimension 型号及尺寸

### 3.1 Model 型号: XC-ISR18650-2.6Ah

### 3.2 Dimension 尺寸

Cell dimension as listed in Figure 3(unit: mm).

电芯尺寸示意图如图所示（单位：mm）。

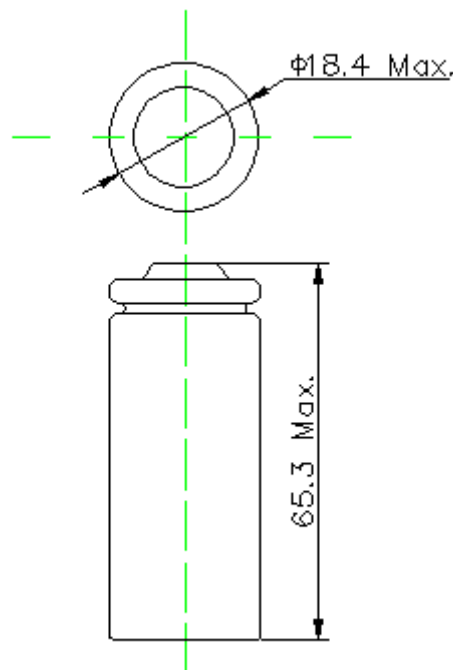

**4. Specification 规格**

ITEM 项目	SPECIFICATION 规格
Normal capacity 标称容量	2600 mAh (0.2C)
Minimum capacity 最小容量	2550 mAh (0.2C)
Normal voltage 标称电压	3.6 V
Charge voltage 充电电压	4.2 ±0.05 V
Discharge end voltage 放电终止电压	2.75 ±0.05 V
Standard charge current 标准充电电流	0.5C(1300 mA)
Standard discharge current 标准放电电流	0.5C(1300 mA)
Max charge current 最大充电电流	1C (Ambient temperature 25°C)(环境温度 25°C)
Max continous discharge current 最大放电电流	2C (Ambient temperature 25°C)(环境温度 25°C)
Pulse Current 脉冲放电	3C (Ambient temperature 25°C)(环境温度 25°C)
Working Temperature 工作温度	Charge 充电: 0°C ~ 45°C Discharge 放电: -20°C ~ 55°C
Recommended Storage temperature 推荐存储温度	15°C ~ 35°C
Internal resistance 内阻	≤60 mΩ(AC Impedance, 1000 Hz)
Cell dimension 电芯尺寸	Height : 65.3 mm Max 最大高度: 65.3 mm Diameter : 18.4mm Max 最大直径: 18.4 mm
Weight 重量	≤ 48g

**5. Technical characteristics 技术要求**
**5.1 Cell use conditions 电芯使用环境**

Charge temperature 充电温度: 0°C ~ 45°C

Discharge Temperature 放电温度: -20°C ~ 55°C

**5.2 Cell testing conditions 电芯试验环境**

All the tests are as follows only if any other is specially stated, :

除非有特殊说明, 所有测试的环境条件要求:

Temperature 温度: 20°C ± 5°C

### 5.3 Electric performance 电性能

NO. 序号	ITEM 测试项目	CRITERION 性能标准	TESTING METHOD 测试条件与方法
5.3.1	Discharge rate performance 倍率放电性能	A) Discharge Performance (0.2C) $\geq 100\%$ Rated Capacity B) Discharge Performance (0.5C) $\geq 95\%$ Rated Capacity C) Discharge Performance (1C) $\geq 90\%$ Rated Capacity D) Discharge Performance (2C) $\geq 80\%$ Rated Capacity  A) 0.2C 放电容量 $\geq 100\%$ 标称容量 B) 0.5C 放电容量 $\geq 95\%$ 标称容量 C) 1C 放电容量 $\geq 90\%$ 标称容量 D) 2C 放电容量 $\geq 80\%$ 标称容量	The cell is charged according to standard charge method, and then, it is discharged to 2.75V using 0.2C current; after, the cell is charged according to standard charge method, and then, it is discharged to 2.75V using 0.5C current; The cell is charged according to standard charge method, and then, it is discharged to 2.75V using 1.0C current; At the end, the cell is charged according to standard charge method, and then, it is discharged to 2.75V using 2.0C current; The discharge capacities under different current shall be recorded. 以标准充电方式进行充电,再以 0.2C 的电流放电至 2.75V;接着以标准充电方式进行充电,再以 0.5C 的电流放电至 2.75V;接着以标准充电方式进行充电,再以 1C 的电流放电至 2.75V;最后以标准充电方式进行充电,再以 2C 的电流放电至 2.75V;记录各个不同电流下的放电容量。
5.3.2	Cycle life 循环寿命	$\geq 300$ cycle	Under room temprature, the cell is charged to 4.2V using 0.5C current and then store it for 10 min. Then it is discharged to 2.75V using 0.5C current. Recycle it continuously till the residual capacity is less than 80% of the rated capacity. 室温的条件下,电池以 0.5C 充电至 4.2V,截止电流 0.02C,搁置 10min,再以 0.5C 放电至 2.75V,按以上工步循环至放电容量小于 80%初始容量,寿命终止。
5.3.3	High-Low temperature discharge performance 高低温放电性能	Discharge capacity/ initial capacity $\times 100\%$ A) $60^\circ\text{C} \geq 95\%$ rated capacity B) $0^\circ\text{C} \geq 80\%$ rated capacity C) $-10^\circ\text{C} \geq 70\%$ rated capacity D) $-20^\circ\text{C} \geq 55\%$ rated capacity No obvious outside damage, No leakage, No smoke, No explosion 放电容量/初始容量 $\times 100\%$ A) $55^\circ\text{C}$ 时 $\geq 95\%$ 标称容量; B) $0^\circ\text{C}$ 时 $\geq 80\%$ 标称容量; C) $-10^\circ\text{C}$ 时 $\geq 70\%$ 标称容量; D) $-20^\circ\text{C}$ 时 $\geq 55\%$ 标称容量。 电池外观无明显变形、不漏液、不冒烟、不爆炸、不起火	Test the batteries' initial state and capacity, after standard charging, store it at $60 \pm 2^\circ\text{C}$ for 3 hours, discharge at $0.2C_5\text{mA}$ to 2.5V, then make standard charging under room temperature. Then Store it at corresponding constant temperature for 3h under $0 \pm 2^\circ\text{C} / -10 \pm 2^\circ\text{C} / -20 \pm 2^\circ\text{C}$ in order. Then discharge the cell at $0.2C_5\text{mA}$ to 2.5V and meanwhile make a capacity record. At last store it at room temperature for 2 hours and observe the cell appearance. 测量电池的初始容量和初始状态,电池标准充电后,在 $55 \pm 2^\circ\text{C}$ 条件下恒温搁置 3h、以 $0.2C_5\text{mA}$ 放电至 2.5V,然后在室温条件下标准充电。依此按照 $0 \pm 2^\circ\text{C} / -10 \pm 2^\circ\text{C} / -20 \pm 2^\circ\text{C}$ 的顺序在相应的恒温条件下搁置 3h,以 $0.2C_5\text{mA}$ 放电至 2.5V,记录电池对应的容量。最后在室温状态下搁置 2h,实验结束。

5.3.4	Storage performance 存储性能	Residual Capacity $\geq 90\%$ Rated Capacity Recovery Capacity $\geq 98\%$ Rated Capacity Internal resistance increase rate $\leq 30\%$ 残余容量 $\geq 90\%$ 标称容量 恢复容量 $\geq 98\%$ 标称容量 内阻增加率 $\leq 30\%$	After standard fully charge, make standard discharge. This capacity is recorded as initial discharge current. Then the cell is fully charged according to standard charge method and stored at 25°C for 28 days. After storage, the cell is discharged according to the requirement of standard discharge method. This discharge capacity is named as the Residual capacity. And then charge and discharge the cell by 0.5C. This discharge capacity is recorded as the Recovery capacity. 电芯以标准充电方式进行充电, 以标准放电方式进行放电, 此容量记为初始放电容量。然后将电芯以标准充电方式充满电后置于 25°C 温度下, 存储 28 天, 存储后以标准放电方式进行放电, 记为残余容量, 然后将电芯以 0.5C 倍率充满电和放完电, 放电容量记为恢复容量。
-------	-----------------------------	--	--

#### 5.4 Environmental characteristics 环境适应性能

NO. 序号	ITEM 测试项目	CRITERION 性能标准	TESTING METHOD 测试条件与方法
5.4.1	Vibration 振动性能	No leakage 、 No flame、 No fire、 No explosion 电芯不泄漏、不起火、不爆炸	After standard charging, fixed the cell to vibration table and subjected to vibration cycling that the frequency is to be varied at the rate of 1Hz per minute between 10Hz and 55Hz, the excursion of the vibration is 1.52mm. The cell shall be vibrated for 90 minutes per axis of x, y axes. 将电池直接或通过夹具安装在振动台的台面上, 按 1Hz/min 速率, 形成 1.52mm, 沿 X、Y、Z 三个方向做频率扫描振动, 每个方向从 10Hz~55Hz 扫频振动 90min $\pm$ 5min, 扫频速率为 1oct/min。
5.4.2	Mechanical shock 机械冲击性能	No leakage 、 No flame、 No fire、 No explosion 电芯不漏液、不冒烟、不起火、不爆炸	In direction X, Y, and Z intersecting one another at right-angles, apply impacts having a minimum mean acceleration of 75G in the first 3mSec and a peak acceleration that falls between 125G and 175G. 机械冲击应在三个相互垂直的 X,Y,Z 每个轴上施加。每次冲击要施加在电芯表面的法线方向上。每次冲击加速在初始 3ms, 最小平均加速度为 75G (G 为加速度)。峰值加速度在 125G~175G 之间。
5.4.3	Temperature Cycling Test 温度循环试验	no leakage, no fire, no explosion 不泄漏, 不起火, 不爆炸	The fully charged batteries are to be placed in a test chamber and subjected to the following cycles: a) Raising the temperature to 75°C $\pm$ 2°C within 30 minutes and maintaining this temperature for 4 hours. b) Reducing the temperature to 20°C $\pm$ 2°C within 30 minutes and maintaining this temperature for 2 hours. c) Reducing the temperature to minus 20°C $\pm$ 2°C (minus 40 $\pm$ 5°F) within 30 minutes and maintaining this temperature for 4 hours. d) Raising the temperature to 20°C $\pm$ 2°C within 30 minutes. e) Repeating the sequence for a further 4cycles. f) After the 5th cycle, storing the batteries for 7 days prior to examination. 充满电的电池: 75°C $\pm$ 2°C 搁置 4h; 20°C $\pm$ 2°C 搁置 2h; -20°C $\pm$ 2°C 搁置 4h; 20°C $\pm$ 2°C 搁置 2h (温度变化时间 $\leq$ 30min)。循环 5 次后, 将电池搁置 7d 进行检测

## 5.5 Safety characteristics 安全性能

NO. 序号	ITEM 测试项目	CRITERION 性能标准	TESTING METHOD 测试条件与方法
5.5.1	Overcharge test 过充测试	No flame、No fire、No explode 不冒烟、不起火、不爆炸	The cell is discharged following the standard discharge method. Apply a 10V power supply and a 3C charge current for 1.5hrs. 电芯按照标准放电方式放完电后,采用 3C 电流 10 V 电压恒流恒压充电 1.5 小时。
5.5.2	130°C hot oven test 130°C 热箱测试	When the temperature of the cell is 130°C. Cell must not fire or explode in 10 minutes 电芯表面温度达到 130°C 后的 10 分钟内,电芯不起火、不爆炸	The cell is charged following the standard charge method. After charging the cell is put in the oven. And then the oven temperature will be ramped at 5°C per minute to 130°C and held at 130°C. When the temperature of the cell reach 130°C, the cell is maintained in the 130°C oven for a maximum of 10 minutes or until a fire or explosion is obtained. 电芯按照标准充电方式充满电后,将电芯放进热箱里,然后将热箱按 5°C/min 升温到 130°C,当电芯的温度也达到 130°C 时,电芯在热箱 130°C 环境下保持 10 分钟或者电芯起火爆炸为止。
5.5.3	Over discharge test 过放测试	No flame、No fire、No explode 电芯不冒烟、不起火、不爆炸	Cell shall first be charged according to standard charge method, and then cell is to be discharged by 0.2C current for 12 hours; The test is completed when the cell is to be discharged up to 250% of rate capacity or the other protective devices prevent the discharge. 电芯按照标准充电方式充满电后,以 0.2C 放电 12 小时直到放电容量达到额定容量的 250%或者保护装置动作为止。
5.5.4	Crush test 挤压测试	No fire、No explode 电芯不起火、不爆炸	After charging a cell following the standard charge method, the cell shall be crushed between two flat surfaces. The direction of the crushing force shall be vertical to axis of the cylinder. The crushing force is to be applied by a hydraulic ram with a 32mm diameter piston. Crushing force is approximately 13 KN. Once the maximum pressure has been obtained it is to be released. 电芯按照标准充电方式充满电后,放在两个平整的表面进行挤压测试,压力器必须施加一个与圆柱电芯轴向垂直的力,平压于电芯。采用 32 mm 直径的液压活塞,所用压力为 13 KN,一旦达到最大压力值,即释放压力。
5.5.5	Short circuit test 短路测试	No fire、No explode 电芯不起火、不爆炸	The battery to be fully charged with standard charging condition, and short the positive and negative terminals with wire resistance=100mΩ. Tests are to be conducted at 23°C ±3°C and at 55°C ±5°C. 电池按照标准充电充满,分别置于 23°C ±3°C 和 55°C ±5°C 环境下,用外部电阻不高于 100mΩ 的电阻将每只电池短路。持续 24h 或外壳温度下降至最高温度的 20% 时,结束试验。
5.5.6	Impact test 重物冲击测试	No flame、No fire、No explode 电芯不冒烟、不起火、不爆炸	Cell shall first be charged according to standard charge method, then the battery cell was placed on a flat surface so that the longitudinal axis of the battery cell shall be parallel with it. A 7.9mm diameter bar is to be placed across the center of the sample. A 9.1kg weight is to be dropped from a height of 61cm on the sample. 电芯按照标准充电方式充满电后,水平放置于一个与电芯纵轴平行的平板。将一直径 Φ7.9mm 的棒放在样品中心,让重量 9.1kg 的重物从 610mm 的高度落到实验电芯上



## 6. Characteristics Curves 性能曲线 (仅供参考)

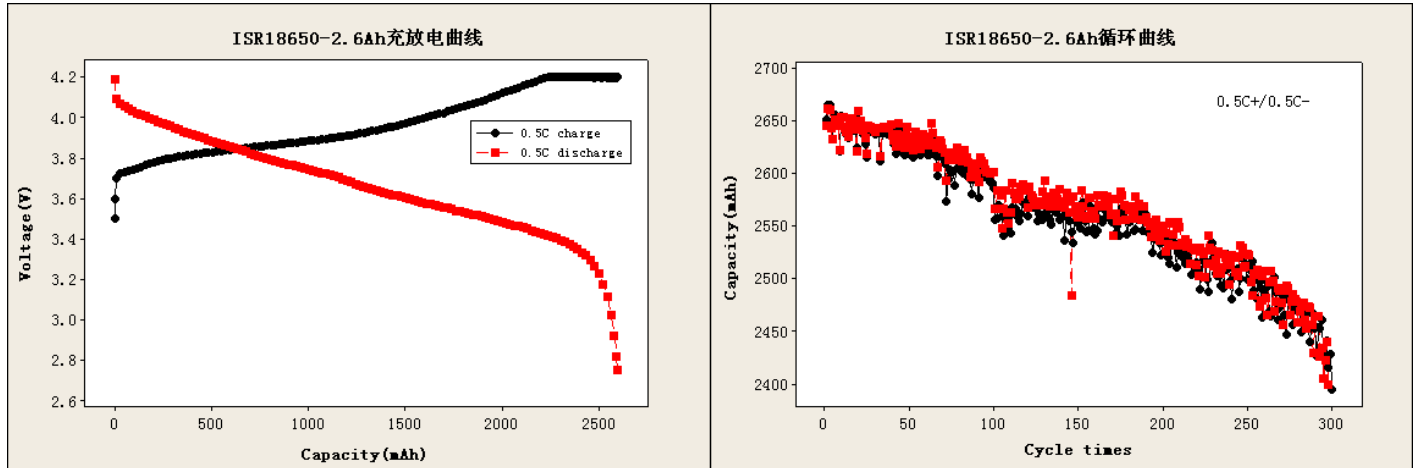

## 7. Storage And Others 储存及其它事项

### 7.1 Long Time Storage 储存

If the battery should be stored under  $-20^{\circ}\text{C} \sim 45^{\circ}\text{C}$ . If it is stored for a long time (exceed three months), the battery should be stored under temperature of  $23^{\circ}\text{C} \pm 3^{\circ}\text{C}$  and humidity of  $65\% \pm 20\% \text{RH}$  at dr and cool place. The battery should be charged and discharged each three months. The battery's storage voltage should be 3.6~3.9V and the battery which is less than 3.4V should be charged to 3.9V with 300mA~2600mA current every three month..

电芯储存温度必须在  $-20^{\circ}\text{C} \sim 45^{\circ}\text{C}$  的范围内, 长期存储电池 (超过 3 个月) 须置于温度为  $23^{\circ}\text{C} \pm 3^{\circ}\text{C}$ 、湿度为  $65\% \pm 20\% \text{RH}$  的环境中。长期贮存电压为 3.6V~3.9V。保质期内每隔 3 个月对电池电压低于 3.4V 的电池用 300mA~2600mA 电流进行补充电至电压达到 3.9V。

### 7.2 Others 其它事项

Any matters that this specification does not cover should be consulted between the customer and XINCHI.

本规格书中未提及的事项, 须经双方协商确定。

## 8. Warranty And Responsibility 保质期及产品责任

Warranty period is six months which begins from the delivery date. XINCHI is not responsible for the incident caused by not obeying the specifications. XINCHI is not responsible for problem due to usage that is not specified in this spec. XINCHI is not responsible for the problem due to improper charge or assembly. When the specification is modified, XINCHI will inform the customer.

保质期是从出厂日期 (喷码) 开始起 6 个月。芯驰光电对因没有按本规格书规定操作而导致的意外不负责任。非按照本规格书规定使用电池造成的电池损坏, 本公司不承担责任。因充电不当、电池配组不当而造成损坏的, 本公司不承担责任。当本规格书有变动时, 恕我司将不会通知购买方。

## 9. Notice In Using Battery 操作注意事项

- Charge current should be less than the maximum value specified in the Product Specification. Charging with higher current than recommended value may cause damage to cells' electrical, mechanical, and safety performance and could lead to heat generation or leakage.

充电电流不得超过本标准中规定的最大充电电流。使用高于推荐值电流充电将可能引起电芯的充放电性能、机械性能和安全性能的问题, 并可能会导致发热或泄漏。

- Batteries shall be charged shall be done by voltage less than that specified in the Product Specification (4.20V/cell). Charging beyond 4.25V, which is the absolute maximum voltage, must be strictly prohibited. The charger and protection circuit of battery pack shall be designed to comply with this condition. It is very dangerous that charging with higher voltage than the maximum value and may cause damage to the cell electrical, mechanical safety performance and could lead to heat generation or leakage.

充电电压不得超过本标准中规定的额定电压 (4.20V/电芯)。4.25V 为充电电压最高极限, 充电器和电池保护



电路的设计应满足此条件。电芯电压高于额定电压值时，将可能引起电芯的充放电性能、机械性能和安全性能的问题，可能会导致发热或泄漏。

● Batteries shall be charged at 0°C-45°C environment temperature specified in the Product Specification. In case of environment temperature is lower than 10°C, batteries shall be charged with a little current (no larger than 0.5C). If the environment temperature is lower than 0°C, charge shall be prohibited.

电芯必须在 0°C-45°C 的环境温度范围内才能进行正常充电。环境温度低于 10°C 时，只能以小电流（不得大于 0.5C）充电；当环境温度低于 0°C 时，应禁止充电。

#### 10. Warning And Matters Need Attention In Using Battery. 电池使用时警告及注意事项

Please pay attention to followings in case of battery will have leakage, heat or explosion. 为防止电池可能发生泄  
漏、发热、爆炸，请注意以下预防措施：

##### Warning! 警告！

- Do not immerse the battery in water or seawater, and keep the battery in a cool dry surrounding if it stands by. 严禁将电池浸入海水或水中，保存不用时，应放置于阴凉干燥的环境中。
- Does not use or leave the battery near a heat source as fire or heater 禁止将电池在热高温源旁，如火、加热器等使用和留置。
- Use the battery charger specifically for that purpose when recharging. 充电时请选用锂离子电池专用充电器。
- Do not reverse the position and negative terminals. 严禁颠倒正负极使用电池。
- Do not connect the battery electrodes to an electrical outlet. 严禁将电池正负端直接插入电源插座。
- Do not discard the battery in fire or a heater. 禁止将电池丢于火或加热器中。
- Do not short-circuit the battery by directly connecting the positive and negative terminals with metal objects. 禁止用金属直接连接电池正负极短路。
- Do not transport or store the battery together with metal objects such as hairpins, necklaces, etc. 禁止将电池与金属,如发夹、项链等一起运输或贮存。
- Do not strike, trample or throw the battery. 禁止敲击或抛掷、踩踏电池等。
- Do not directly solder the battery and pierce the battery with a nail or other sharp objects. 禁止直接焊接电池和用钉子或其它利器刺穿电池。

##### Becareful! 小心！

- Do not use or leave the battery at high temperature (for example, at strong direct sunlight or in a vehicle in extremely hot weather). Otherwise, it can overheat or fire or its performance will be degenerate and its service life will be decreased 禁止在高温下（炙热的阳光下或很热的汽车中）使用或放置电池，否则可能会引起电池过热、起火或功能失效、寿命减短。
- Do not use the battery in a location where static electricity and magnetic field is great, otherwise, the safety devices may be damaged, causing hidden trouble of safety. 禁止在强静电和强磁场的地方使用,否则易破坏电池安全保护装置,带来不安全的隐患。
- If the battery leaks and the electrolyte gets into the eyes, do not rub the eyes, instead, rinse the eyes with clean water, and immediately seek medical attention. Otherwise, it may injure eyes. 如果电池发生泄露,电解液进入眼睛,请不要揉擦,应用清水冲洗眼睛,并立即送医治疗,否则会伤害眼睛。
- If the battery gives off strange odor, generates heat, becomes discolored or deformed, or in any way appear abnormal during use, recharging or storage, immediately remove it from the device or battery charger and stop using it. 如果电池发出异味,发热、变色、变形或使用、贮存、充电过程中出现任何异常,立即将电池从装置或充电器中移离并停用。
- In case the battery terminals are dirty, clean the terminals with a dry cloth before use. Otherwise poor performance may occur due to the poor connection with the instrument. 如果电极弄脏,使用前应用于干布抹净,否则可能会导致接触不良功能失效
- Be aware of discarded batteries may cause fire or explosion; tape the battery terminals to insulate them 废弃之电池应用绝缘纸包住电极,以防起火、爆炸。